

Design Features

- Digital and Analog modes operate simultaneously.
- Programmable Flow Configurations.
- Multi-Drop Capability of up to 256 units.
- Stores calibration data for up to 10 gases.
- Totalizer indicates total gas quantity.
- Alarm limits for high and low gas flow.
- Conversion factors for up to 256 gases.
- Auto Tune function for optimum control response.
- Self-Diagnostic Tests.



Programmable Mass Flow Controller with Digital Signal Processing

Microprocessor driven **digital** flow controllers allow one to program, record, and analyze flow rates of various gases with a computer via an RS-485 interface

Optional RS-232 is available.

Controllers can be programmed for various control functions including flow set point, totalizer, stop totalizer, read totalizer, totalizer from preset flow, stop at preset total, auto zero, and more.

Principles of Operation

Metered gases are divided into two laminar flow paths, one through the primary flow conduit, and the other through a capillary sensor tube. Both flow conduits are designed to ensure laminar flows and therefore the ratio of their flow rates is constant. Two precision temperature sensing windings on the sensor tube are heated, and when flow takes place, gas carries heat from the upstream to the downstream windings. The resultant temperature differential is proportional to the change in resistance of the sensor windings.

A Wheatstone bridge design is used to monitor the temperature dependent resistance gradient on the sensor windings which is linearly proportional to the instantaneous rate of flow. The output of the Wheatstone bridge is converted to digital format with a 12 Bit ADC (analog to digital converter).

An on-board microprocessor and non-volatile memory store all calibration factors and directly control a proportionating electromagnetic valve. The digital closed loop control system continuously compares the mass flow output with the selected flow rate. Deviations from the set point are corrected by compensating valve adjustments, with PID algorithm thus maintaining the desired flow parameters with a high degree of accuracy. Output signals of 0 to 5Vdc or 4 to 20mA are generated indicating mass molecular based flow rates of the metered gas.

Interface

The **digital interface** operates via RS485 (optional RS232) and provides access to applicable internal data including **FLOW SET POINT, ACTUAL FLOW, ZERO ADJUSTMENTS, and LINEARIZATION TABLE ADJUSTMENTS.**

The analog interface provides 0 to 5Vdc, 0 to 10Vdc and 4 to 20 mA inputs and outputs.

Auto Zero

The DFC automatically nulls the sensor zero offset whenever the flow set point is below 2% of full scale. To accommodate this feature the control valve must fully close under that condition. Provisions are made to either disable, force or store the current auto zero via digital commands.

Totalizer

The firmware for the DFC provides functions to register total gas quantity. The total mass of gas is calculated by integrating the actual gas flow rate with respect to time.

Digital interface commands are provided to:

- SET the totalizer to ZERO.
- START /STOP totalizing the flow.
- READ the totalizer.
- START the totalizer at a preset flow.
- STOP the flow at a preset total.

Multi-Gas Calibration

The DFC is capable of storing primary calibration data for up to 10 gases. This feature allows the same DFC to be calibrated for multiple gases while maintaining the rated accuracy on each.



Optional Display

Conversion Factors

Conversion factors for up to 256 gases are stored in the DFC. Conversion factors may be applied to any of the ten gas calibrations via digital interface commands.

Flow Alarms

High and Low gas flow ALARM limits are programmed using the digital interface. Alarm conditions are reported via the digital interface or can activate the contact closure outputs.

Programmable Flow

Aalborg software supports programmable flow modes, allowing execution of custom programming of up to ten steps. Various flow configurations include ramping, linearized increasing and decreasing modes.



Auto Tune

The AUTO TUNE function allows the DFC to automatically optimize control response for the gas under actual process conditions. During the AUTO TUNE process, the instrument adjusts PID gains for optimum step response and determine key control valve characteristics (only available on units with less than 80 L/min maximum flow).

Contact Closure

Two sets of dry contact relay outputs are provided to actuate user supplied equipment. These are programmable via the digital interface such that the relays can be made to switch when a specified event occurs (e.g. when a low or high flow alarm limit is exceeded or when the totalizer reaches a specified value).

Valve Override

Means are provided to force the control valve fully open (purge) or fully closed via either the analog or digital interfaces.

Self-Diagnostics

Whenever power is first applied, the DFC runs a series of SELF-DIAGNOSTIC TESTS to ensure that it is in optimum working condition.

Engineering Units

The flow set point, measured gas flow and associated totalizer data is scaled directly in engineering units via digital interface commands.

TABLE 18 - SPECIFICATIONS

ACCURACY (including linearity):	15 °C to 25 °C and 10 to 60 psia (0.7-4 bars): ±1% of FS, 0 °C to 50 °C and 5 to 150 psia (0.3-10 bars): ±2% of FS, ±1% of FS at a specific temperature and pressure with special calibration.
REPEATABILITY:	±0.15% of full scale.
RESPONSE TIME:	0.6 to 1.0 second to within ±2% of set point over 20% to 100% of full scale.
TEMPERATURE COEFFICIENT:	0.05% of full scale/ °F or better.
PRESSURE COEFFICIENT:	0.01% of full scale /psi (0.07 bar) or better.
OPTIMUM GAS PRESSURE:	25 psig (1.73 bars).
MAXIMUM GAS PRESSURE:	1000 psig (70 bars).
MAXIMUM DIFFERENTIAL PRESSURE:	50 psig (3.4 bars) for DFC26 and DFC36 40 psig (2.8 bars) for DFC46
MAX PRESSURE DROP:	Refer to Table 20.
GAS and AMBIENT TEMP:	41 °F to 122 °F (5 °C to 50 °C)
COMMUNICATION INTERFACE:	RS485 - Standard. RS232 - Optional.
OUTPUT SIGNALS:	Linear 0-5 Vdc (2000 ohms min load impedance); impedance); 0-10Vdc (4000 ohms min impedance); 4-20 mA optional (0-500 ohms\ loop resistance). Maximum noise 20mV peak to peak.
CIRCUIT PROTECTION:	Circuit boards have built-in polarity reversal protection. Resettable fuses provide power input protection.
**MATERIALS IN FLUID CONTACT:	316 stainless steel, 416 stainless steel, Viton® O-rings. Optional O-rings: Buna®, EPR and Kalrez®.
ATTITUDE SENSITIVITY:	No greater than +15 degree rotation from horizontal to vertical; standard calibration is in horizontal position.
CONNECTIONS:	Model DFC26 standard 1/4" compression fittings, Model DFC36 standard 1/4" compression fittings, Model DFC46: standard 3/8" compression fittings, Optional 1/8" or 3/8" compression fittings and 1/4" VCR® fittings available.
LEAK INTEGRITY:	1 x 10 ⁻⁹ smL/sec of helium maximum to the outside environment.
TRANSDUCER INPUT POWER:	±15Vdc, 450 mA maximum.
CALIBRATION OPTIONS:	Standard 10 point NIST traceable calibration. Optional up to 9 additional 10 point calibrations may be ordered for an additional charge.
CE COMPLIANCE:	EN 55011 class 1, class B; EN50082-1.

***The selection of materials of construction, is the responsibility of the customer. The company accepts no liability.*

DFC26 Mass Flow Controller

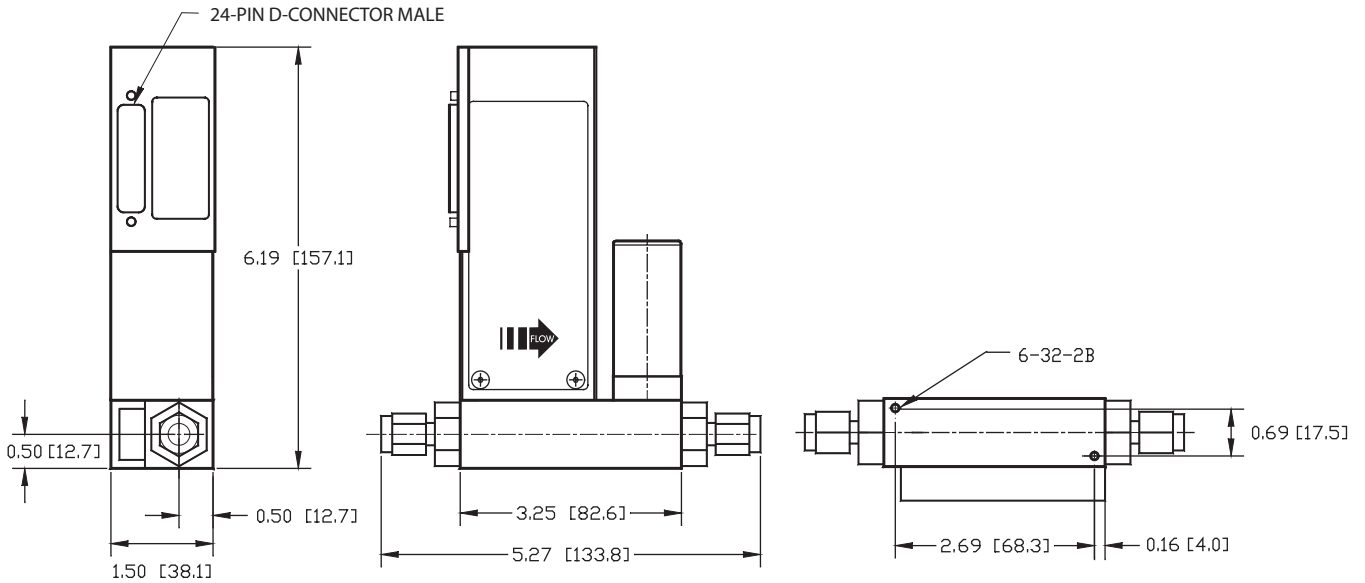

DFC36 / 46 Mass Flow Controller

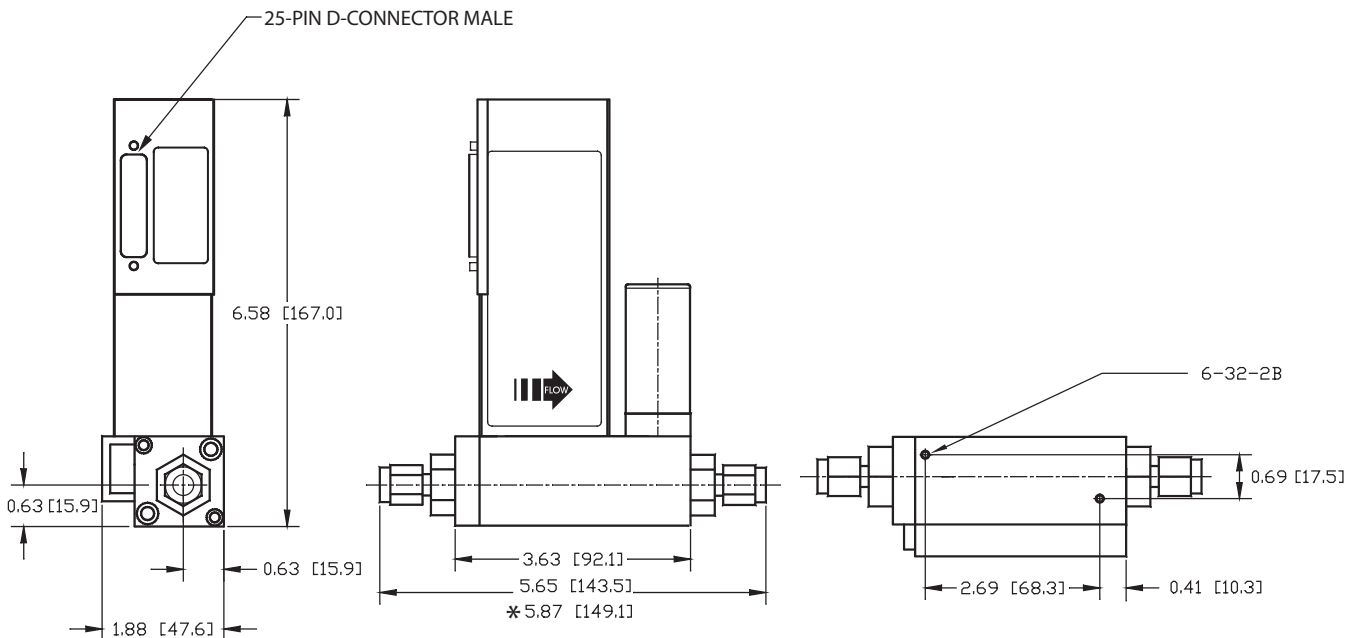

* FOR HIGH FLOW MASS FLOW CONTROLLERS

TABLE 19 - FLOW RANGES FOR DFC

DFC 26 LOW FLOW CONTROLLERS	
CODE	Units [Nitrogen]
01	0 to 10 smL/min
02	0 to 20 smL/min
03	0 to 50 smL/min
04	0 to 100 smL/min
05	0 to 200 smL/min
06	0 to 500 smL/min
07	0 to 1 sL/min
08	0 to 2 sL/min
09	0 to 5 sL/min
10	0 to 10 sL/min
DFC 36 MEDIUM FLOW CONTROLLERS	
CODE	sL/min [N ₂]
11	0 to 15 sL/min
30	0 to 20 sL/min
31	0 to 30 sL/min
32	0 to 40 sL/min
33	0 to 50 sL/min
DFC 46 HIGH MASS FLOW CONTROLLERS	
CODE	sL/min [N ₂]
40	0 to 60 sL/min
41	0 to 80 sL/min
42	0 to 100 sL/min

The following units of measure are supported: % of FS, mL/min, mL/hr, scfm, scfh, sL/min, sL/hr, lbs/hr, lbs/min, and one user defined unit of measure.

Leak Integrity

1 x 10⁻⁹ smL/sec of Helium maximum to the outside environment.

Balanced Power Supply

The DFC operates on ±15Vdc. The current requirements for the positive and negative power supplies are balanced such that the current in the power supply common connection is minimized. Maximum power consumption is 13.5 watts at ±15Vdc.

TABLE 21 - MAXIMUM PRESSURE DROP FOR DFC

MODEL NO.	MAX. FLOW (N ₂)	MAXIMUM PRESSURE DROP		
		[mm H ₂ O]	[psid]	[mbar]
DFC 26	up to 10	720	1.06	75
	15	2630	3.87	266
DFC 36	20	1360	2.00	138
	30	2380	3.50	241
	40	3740	5.50	379
DFC 46	50	5440	8.00	551
	60	7480	11.00	758
	100	12850	18.89	1302

TABLE 20 - ACCESSORIES AND READOUTS FOR DFC

CBL-DFC	25 pin D-connector with 6 ft. wire to computer port stripped, Branch 6ft. wire to customers power supply.
CBL-DFC-DPM-AIO	Cable stripped for DFC with LCD jack and analog input/output.
CBLDFC-PROC	25 pin D-connector with 6ft. wire to 15 pin DM, Branch 6ft. wire to computer port stripped.
PS-DFC-110NA-5-S	Power supply with 25 pin female D-connector 110/vac (±15Vdc.) Branch 6ft wire to computer port stripped /North America.
PS-DFC-110NA-5-A	Power supply with 25 pin D-connector, analog interface 110/vac (+ - 15Vdc.) (North America).
PS-DFC-230EU-5-S	Power supply with 25 pin female D-connector 230/vac (±15Vdc.) Branch 6ft wire to computer port stripped /Europe.
PS-DFC-240UK-5-S	Power supply with 25 pin female D-connector 240/vac (±15Vdc.) Branch 6ft wire to computer port stripped /United Kingdom.
PS-DFC-240AU-5-S	Power supply with 25 pin female D-connector 240/vac (±15Vdc.) Branch 6ft wire to computer port stripped /Australia.
BCKUPEG-DFC	Digital panel meter / led backlight.
PS-DFC-110NA-5-S-D	Power supply DFC 110/Vac +/-15Vdc standard interface and LCD jack. (United States).
PS-DFC-110NA-5-A-D	Power supply DFC 110/Vac +/-15Vdc analog interface and LCD jack. (United States).

Cable Options

Standard Cable (supplied with Transducer) CBL-DFC

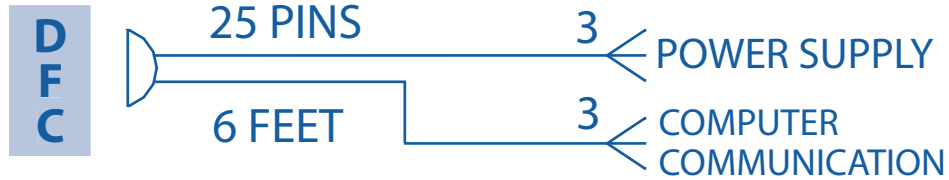

CBL-DFC-SDPROC

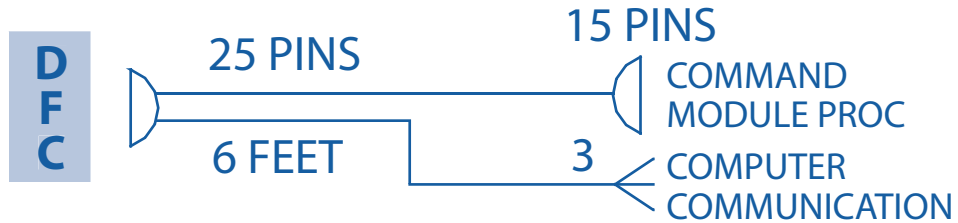

PS-DFC-110NA-5-S 230EU /240UK /240AU

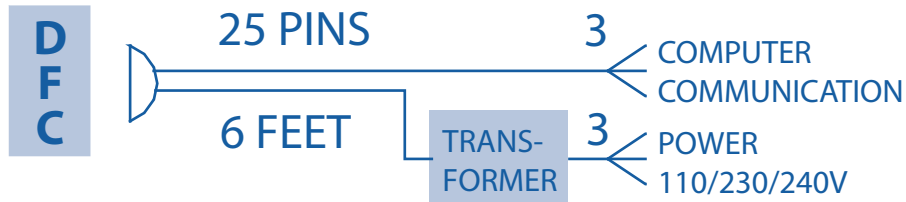

PS-DFC-110NA-5-A
230EU /240UK /240AU

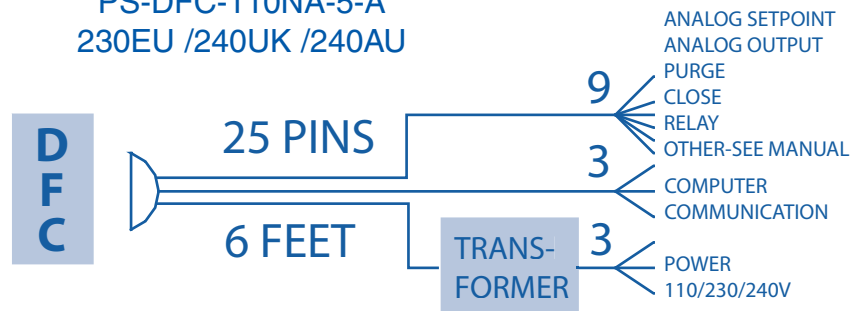

DFC	MODEL
MAX. FLOW (N ₂)	
26	10 L/min
36	50 L/min
46	100 L/min
MATERIAL	
S	Stainless Steel
SEALS	
V	Viton®
B	Buna®
E	EPR
T	PTFE / Kalrez®
FITTINGS	
A	1/4" Compression
B	1/8" Compression
C	1/4" VCR®
D	3/8" Compression
CONNECTOR	
D	D Connector
DISPLAY	
N	No Display
L	LCD Readout
POWER	
5	±15 Vdc
INPUT / OUTPUT SIGNAL	
C	0-5Vdc/ 0-5Vdc
D	0-5Vdc/ 4-20mA
E	4-20mA/ 4-20mA
F	4-20mA/ 0-5Vdc
DIGITAL INTERFACE	
2	RS232
5	RS485

DFC 36 S — V A D N 5 — C 5

EXAMPLE: DFC36S-VADN5-C5 50L/min [N₂] 20 psig

SPECIFY: GAS, FLOW RANGE and PRESSURE.

DFC36 stainless steel, Viton® seals, 1/4" compression fittings, D Connector, No display, ±15 Vdc power, 0-5 Vdc/0-5 Vdc input output signal, RS485 digital interface.