



Multi parameter flow meters provide accurate data on three different fluid parameters:

- flow
- pressure
- temperature

The flow rate can be displayed in volumetric flow or mass flow engineering units for standard or actual (temperature, pressure) conditions. Flow meters can be programmed locally by the four button keypad and LCD or remotely via RS-232/RS-485 interface. DFM flow meters support various functions including: flow totalizer, flow, temperature, pressure alarms, automatic zero adjustment, 2 relay outputs, 0-5 Vdc / 0-10 Vdc / 4-20 mA analog outputs for flow, pressure and temperature.

Interface

All features of the flow meter can be accessed via the local four button keypad and LCD. The digital interface operates via RS485 (optional RS-232 is available) and provides access to applicable internal data including: flow, temperature, pressure reading, auto zero, totalizer and alarms settings, gas table, conversion factors and engineering units selection, dynamic response compensation and linearization table adjustment. The analog interface provides 0 to 5Vdc or 0 to 10Vdc or 4 to 20 mA outputs for flow, pressure and temperature (jumper selectable).

Specifications

MODELS 27, 37, 47:

FLOW ACCURACY WITH TEMP/PRESS HARDWARE (INCLUDING LINEARITY):
 $\pm 1\%$ of FS for 0°C to 50°C (32°F to 122°F) and 0.35 to 6.8 bars (5 to 100 psia).

MODELS 26, 36, 46:

FLOW ACCURACY W/O TEMP/PRESS HARDWARE (INCLUDING LINEARITY):
 1.0% of full scale, including non-linearity, at calibration temperature and pressure.

PRESSURE RANGE (MEASUREMENT):

0.34 to 6.8 bars (5 to 100 psia).

PRESSURE ACCURACY:

$\pm 1\%$ of FS.

TEMPERATURE RANGE (MEASUREMENT):

0°C to 50°C (32°F to 122°F).

TEMPERATURE ACCURACY:

$\pm 1^\circ\text{C}$.

REPEATABILITY:

$\pm 0.15\%$ of full scale.

RESPONSE TIME:

0.6 to 1.0 second to within $\pm 2\%$ of set point over 20% to 100% of full scale.

TEMP. COEFFICIENT:

0.15% /°C or better.

PRESSURE COEFFICIENT:

0.01% of full scale/ 0.07 bar (1 psi) or better.

OPTIONAL GAS PRESSURE:

1.73 bars (25 psig).

MAX. GAS PRESSURE:

6.8 bars (100 psia).

MAX. BURST PRESSURE:

13.6 bars (200 psia).

MAX. PRESSURE DROP:

0.55 bars (8 psi) at 100 L/min flow.

GAS & AMBIENT TEMP:

5°C to 50°C (41°F to 122°F).

OUTPUT SIGNALS:

Linear 0-5 Vdc (3000 ohms min load impedance);
 0-10Vdc (6000 ohms min impedance);
 4-20 mA optional (500 ohms max loop resistance).
 Maximum noise 20mV peak to peak.

INPUT POWER:

May be configured for three different options:
 $\pm 15\text{Vdc}$ ($\pm 200\text{ mA}$ maximum);
 $+12\text{Vdc}$ (300 mA maximum);
 $+24\text{Vdc}$ (250 mA maximum);
 Circuit boards have built-in polarity reversal protection.
 Resettable fuses provide power input protection.

MATERIALS IN FLUID CONTACT:

316 stainless steel, Viton® O-rings.
 EPR, Buna or Kalrez® O-rings optional.

CONNECTIONS:

Model DFM26 standard 1/4" compression fittings,
 Model DFM36 standard 1/4" compression fittings,
 Model DFM46 standard 3/8" compression fittings.
 Optional 1/8" or 3/8" compression fittings and 1/4" VCR fittings are available.

DISPLAY:

128x64 graphic LCD with backlight (up to 8 lines of text).

CALIBRATION OPTIONS:

Standard one 10 points NIST calibration.
 Optional up to 9 additional calibrations may be ordered for an additional charge.

CE COMPLIANCE:

EN 55011 class 1, class B; EN50082-1.

ENVIRONMENTAL (PER IEC 664):

Installation Level II; Pollution Degree II.

Auto Zero

The DFM supports automatic sensor zero offset adjustment which can be activated locally via the keypad or remotely via digital interface. The auto zero feature requires absolutely no flow through the meter during auto zero process. Provisions are made to either start, read, or save the current auto zero value via digital commands.

Totalizer

The total volume of the gas is calculated by integrating the actual gas flow rate with respect to time. Both keypad menu and digital interface commands are provided to:

- set the totalizer to ZERO
- start the totalizer at a preset flow
- assign action at a preset total volume
- start/stop totalizing the flow
- read totalizer

Totalizer conditions become true, when the totalizer reading and the "Stop at Total" volumes are equal.

Flow Alarm

High and Low gas flow ALARM limits can be preprogrammed via keypad or remotely via digital interface. ALARM conditions become true when the current flow reading is equal or higher/lower than corresponding values of high and low alarm levels. Alarm action can be assigned with preset delay interval (0-3600 seconds) to activate the contact closer (separate for High and Low alarm).

Pressure Alarm

High and Low gas pressure ALARM limits can be preprogrammed via the keypad or remotely via digital interface. Pressure alarm conditions become true when the current pressure reading is equal or higher than corresponding values of high pressure alarm settings or equal or lower than corresponding values of low pressure alarm settings. Alarm action can be assigned to activate the contact closer (separate for High and Low pressure alarm).

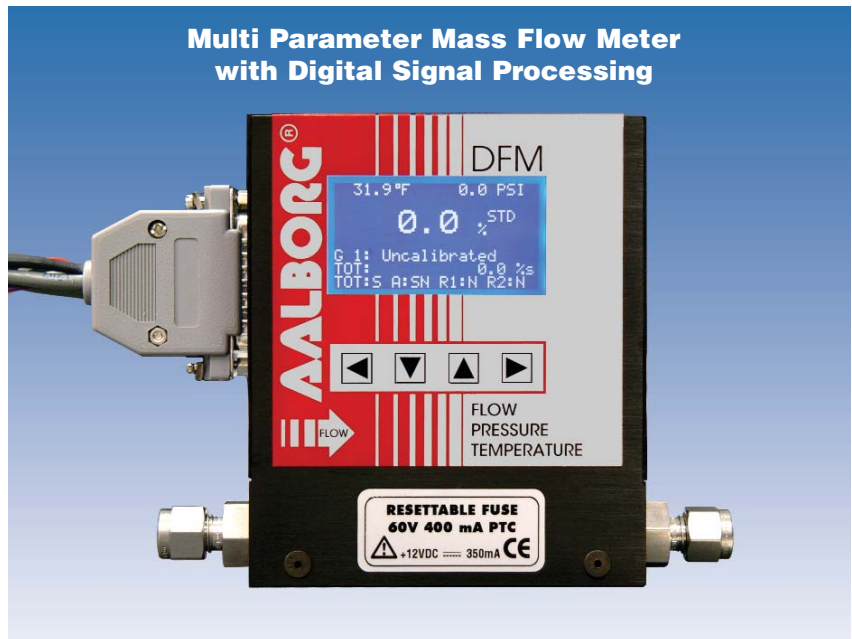

Temperature Alarm

High and Low gas temperature ALARM limits can be preprogrammed via the keypad or remotely via digital interface. Temperature alarm conditions become true when the current temperature reading is equal or higher than corresponding values of high temperature alarm settings or equal or lower than corresponding values of low temperature alarm settings. Alarm action can be assigned to activate the contact closer (separate for High and Low temperature alarm).

Engineering Units

The measured gas flow and associated totalizer data are scaled directly in engineering units via the front panel keypad or digital interface. The following units of measure are supported: %F.S., L/min, L/h, mL/min, mL/h, scuft/h, scuft/min, lb/h, lb/min, one user defined engineering unit.

Multi-Gas Calibration

The DFM is capable of storing primary calibration data for up to 10 gases. This feature allows the same DFM to be calibrated for multiple gases while maintaining the rated accuracy on each.

Conversion Factors

Conversion factors for up to 32 gases are stored in the DFM. In addition provision is made for a user defined conversion factor. Conversion factors may be applied to any of the ten gas calibrations via keypad or digital interface commands.

Contact Closure

Two sets of dry contact relay outputs are provided to actuate user supplied equipment. These are programmable via the local keypad or digital interface such that the relays can be made to switch when a specified event occurs (e.g. when a low or high flow, pressure or temperature alarm limit is exceeded or when the totalizer reaches a specified value).

Leak Integrity

1×10^{-9} smL/sec of Helium maximum to the outside environment.

DFM's are offered either as a Digital Mass Flow Meter, Model Numbers, DFM26, 36, & 46 or as a Digital Multi-Parameter Meter, Model Numbers, DFM27, 37 & 47.

Model Numbers correspond to the following flow rates (based on N₂) for sizing purposes:

DFM26 & DFM27: 0-10, 0-20, 0-50, 0-100, 0-200, 0-500mL/min., 0-1, 0-2, 0-5, & 0-10L/min.

DFM36 & DFM37: 0-15, 0-20, 0-30, 0-40, & 0-50L/min.

DFM46 & DFM47: 0-60, 0-80, & 0-100L/min.

There are 3 voltage (power) options: +/-15Vdc, 12Vdc, & 24Vdc.

RS485 is standard, no cost optional RS232 is selected by changing last digit of part number from 5 to 2. Example: DFM26S-VADL2-A5 indicates RS485, DFM26S-VADL2-A2 indicates RS-232.

1/4" compression fittings standard: DFM26, 36, 27, AND 37. 3/8" compression fittings standard on: DFM46 and 47.

Design Features

- Multi-Drop Capability of up to 255 units (for RS-485 option).
- Stores calibration data for up to 10 different gases.
- Supports 10 different engineering units including user defined.
- Programmable 12 digits Totalizer indicates total gas volume.
- Flow Alarm limits for high and low gas flow with relay output.
- Pressure Alarm limits for high and low gas pressure with relay output.
- Temperature Alarm limits for high and low gas temperature with relay output.
- Four button keypad and large 128x64 graphical LCD with back light.
- Digital (RS-232 or RS-485) and Analog outputs operate simultaneously.
- Internal Conversion factors for up to 32 gases.
- Automatic Zero Adjustment.
- Self Diagnostic Tests.

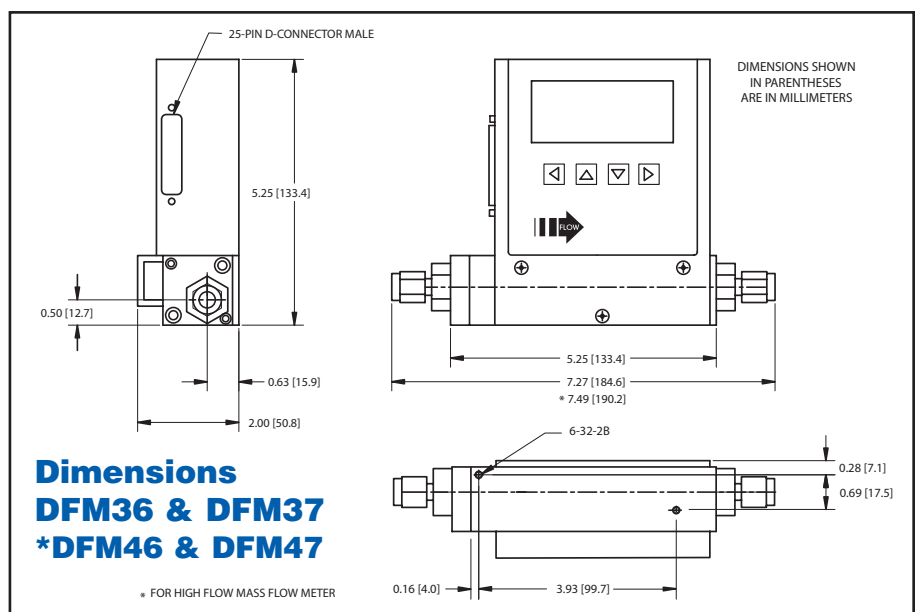
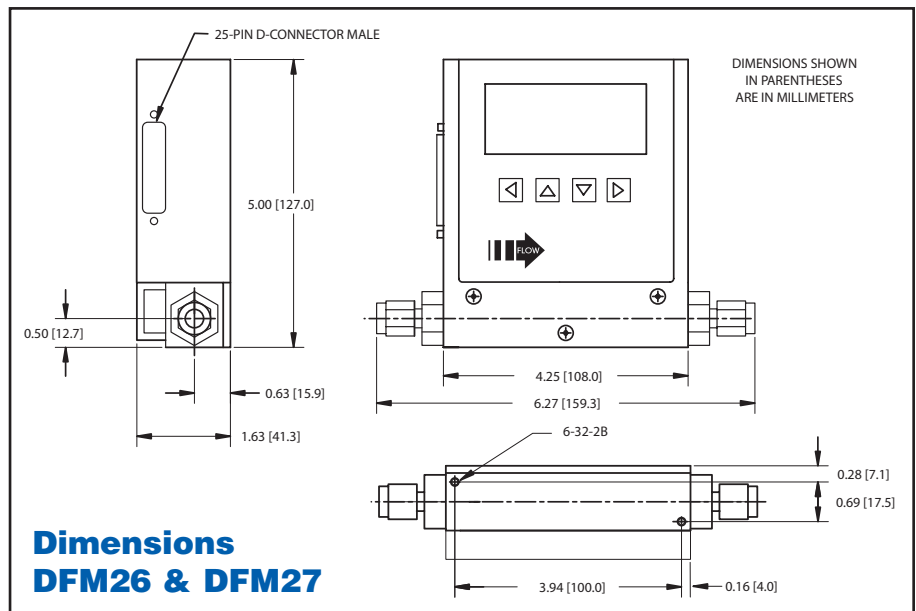



Communication and Power Interface Cable Included with DFM

MODEL	FLOW RATE [std liters/min]	MAXIMUM PRESSURE DROP FOR DFM		
		[mm H ₂ O]	[psid]	[kPa]
DFM 26/27	up to 10	25	0.04	0.276
	20	300	0.44	3.03
DFM 36/37	30	800	1.18	8.14
	40	1480	2.18	15.03
	50	2200	3.23	22.3
DFM 46/47	60	3100	4.56	31.4
	100	5500	8.08	55.7

FLOW RANGES			
DFM 26/27 LOW FLOW MASS METERS			
CODE	smL/min [N ₂]	CODE	sL/min [N ₂]
01	0 to 10	07	0 to 1
02	0 to 20	08	0 to 2
03	0 to 50	09	0 to 5
04	0 to 100	10	0 to 10
05	0 to 200		
06	0 to 500		
DFM 36/37 MEDIUM FLOW MASS FLOW METERS			
CODE	sL/min [N ₂]		
11	0 to 15		
30	20		
31	30		
32	40		
33	50		
DFM 46/47 HIGH FLOW MASS FLOW METERS			
CODE	sL/min [N ₂]		
40	60		
41	80		
42	100		

ORDERING INFORMATION for DFM

SERIES	MAX. FLOW (N ₂)	SEALS	FITTINGS	FOR MODEL	CONNECTOR	DISPLAY	POWER	INPUT/OUTPUT SIGNAL	TEMP & PRESSURE OUTPUT SIGNAL	DIGITAL INTERFACE	LABELS
26	10 L/min	V Viton	A 1/4" Compr	26, 27, 36, 37	D D Connector	L LCD readout	2 12 Vdc	A n.a. 0-5 Vdc	A only 26, 36, 46	2 RS232	A Aalborg
36	50 L/min	B Buna	B 1/8" Compr	26 & 27			4 24 Vdc	B n.a. 4-20 mA		5 RS485	
46	100 L/min	E EPR	C VCR	26, 27, 36, 37			5 ±15 Vdc				
27	10 L/min	T Teflon/Kalrez	D 3/8" Compr	36, 37, 46, 47							
37	50 L/min		X Special								
47	100 L/min	S Stainless									

DFM **36** **S** - **V** **A** **D** **L** **5** - **A** **A** **5** **A**

EXAMPLE: DFM36S-VADL5-AA5A 50 L/min N₂ PLEASE SPECIFY: Gas, Flow Range and Pressure.

DFM36 Stainless, Viton seals, 1/4" Compression Fittings, D Connector, LCD Readout Display, ±15 Vdc Power, 0-5Vdc Output Signal, RS485 Digital Interface, Aalborg Label.