

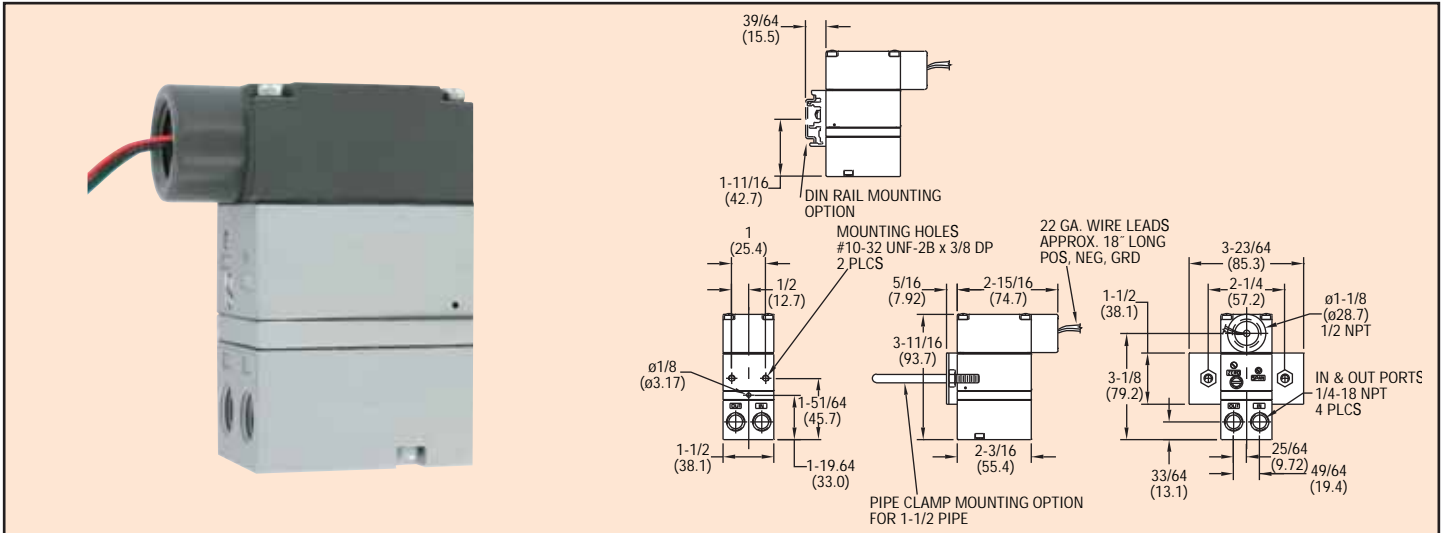

Series
2700 &
2800

Current to Pressure Transducer

NEMA 4X Enclosure, Compact Size, Reliable, Vibration Resistant



The Series 2700 Current to Pressure Transducer combines economical startup cost, low air consumption, and reliable performance to make the 2700 a great investment. The unit converts a variable current signal to a proportional pneumatic output. It has input and output ports on both the front and back which allows for versatile plumbing. The NEMA 4X enclosure enables the unit to be installed indoors or outdoors, however, the unit is not vibration resistant. It is FM and CSA approved for intrinsically safe operation. The 2700 is designed for remote or panel mounting. An integral volume booster provides high flow capacity, increasing control speed in critical applications. Other features include external zero and span adjustments which are convenient for field calibration.

The Series 2800 Current to Pressure Transducer utilizes a closed loop pressure feedback system that closely controls output and compensates for vibration, mounting angle, temperature, and supply pressure variations. These characteristics make this unit ideal for field mounting on a valve. The control mechanism is a piezoceramic actuator encapsulated in a protective skin, which provides a constant defense against humidity and contaminants. These features make this unit ideal for use in demanding applications. The 2800 also comes in a NEMA 4X enclosure and is field reversible. It is FM and CSA approved intrinsically safe, as well. For ease of installation, this model has input and output ports on both the front and back and can be easily panel mounted.

SERIES 2700

Model Number	Input	Output
2713-WP	4-20 mA	3-15 psig (0.2-1.0 bar)
2716-WP	4-20 mA	6-30 psig (0.4-2.1 bar)

SERIES 2800

Model Number	Input	Output
2813-WP	4-20 mA	3-15 psig (0.2-1.0 bar)
2816-WP	4-20 mA	6-30 psig (0.4-2.1 bar)

ACCESSORIES

A-180 Valve Mounting Kit, for Hi-Flow™ control valves (Series 2800 only)

A-181 DIN Rail Mounting Kit, suitable for EN-50035, EN-50042, and EN-50022 rails

A-182 Pipe Mounting Kit, for 1-1/2" and 2" pipes

Valve Mount: For factory mounting and calibration to Hi-Flow™ control valves, add Current-to-Pressure Transducer model number as suffix (Series 2800 only)

SPECIFICATIONS

Service: Oil free, clean dry air filtered to 40 microns.

Input Signal: 4-20 mA.

Air Supply: Minimum: 5 psig (0.3 bar) above maximum output; Maximum: 100 psig (6.9 bar).

Output: 3 to 15 psig (0.2 to 1.0 bar), 6 to 30 psig (0.4 to 2.1 bar).

Accuracy: Series 2800: ±0.1% of span.

Linearity: Series 2700: <±0.5% of span.

Hysteresis: Series 2700: <0.5% of span; Series 2800: ±0.1% of span.

Repeatability: Series 2700: <0.5% of span; Series 2800: ±0.1% of span.

Deadband: Series 2800: 0.02% of span.

Supply Pressure Sensitivity: Series 2700: <0.1% of span per 1.0 psig (0.1 bar).

Power Requirement: Loop powered.

Temperature Limits: Series 2700: -20 to 150°F (-29 to 66°C); Series 2800: Operating: -40 to 160°F (-40 to 71°C); Storage: -40 to 200°F (-40 to 93°C).

Pressure Connections: 1/4" female NPT.

Electrical Connection: 1/2" female NPT.

Air Consumption: Series 2700: 0.03 scfm (0.01 l/s) at midrange typical; Series 2800: 0.025 scfm (0.01 l/s) at midrange typical.

Output Capacity: 4.5 scfm (2.1 l/s) at 25 psig (1.7 bar) supply; 12.0 scfm (5.7 l/s) at 100 psig (6.9 bar) supply.

Enclosure: Chromate-treated aluminum with epoxy paint.

Enclosure Rating: NEMA 4X (IP65) and intrinsically safe.

Weight: Series 2700: 1.3 lb (0.59 kg); Series 2800: 0.8 lb (0.37 kg).

Agency Approvals: CE, CSA, FM.

SERIES 2700

FM Intrinsically Safe Ratings:

Class I, II, III, Division 1, Groups C, D, E, F and G; Class I, Division 2, Groups A, B, C and D; Class II and III, Division 2, Groups F and G.

CSA Intrinsically Safe Ratings: Class I, Division 2, Groups C and D; Class II, Groups E, F and G; Class III.

SERIES 2800

FM Intrinsically Safe Ratings:

Class I, II, and III, Division 1, Groups C, D, E, F, and G; Class I, Zone 0, Group IIB; Class I, II, and III, Division 2, Groups A, B, C, D, F, and G.

CSA Intrinsically Safe Ratings:

Class I, Division 2, Groups A, B, C and D; Class II, Division 2, Groups F and G; Class III.