

MODEL H-600-P H-600A-P 面積式流量計

MODEL H-600P

316SS, 304SS PP, PVC, PVDF REED SWITCH
由令插管 壓克力保護管

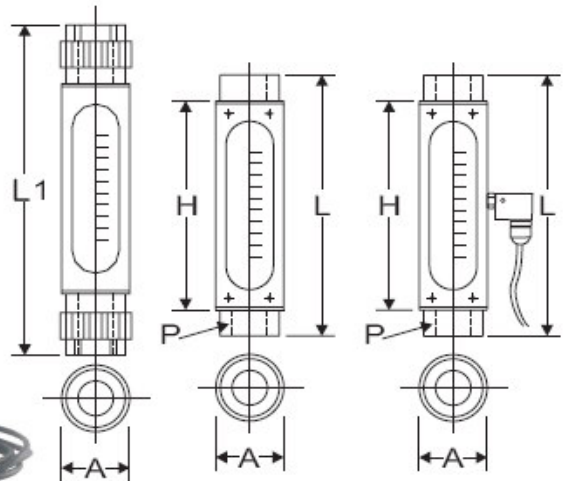

DIMENSIONS PS.PW.PV.PP.PD m/m

MODEL	10	15	18	20	25	32	40	50
L	200	230	230	280	284	284	300	300
L1	165	190	190	240	240	240	240	240
H	165	190	190	240	240	240	240	240
A ϕ	34	42	48	48	60	76	89	101
P	1/4	1/2	1/2	3/4	1	1 1/4	1 1/2	2

STANDARD FLOW RANGE

FLUID SIZE	RANGE			
	WATER	L/MIN.	AIR	NL/MIN
10	1 0.03-0.3	3 0.08-0.8	5 0.5-5.0	7 1-15
	2 0.05-0.5	4 0.1-1.0	6 1-10	8 2-20
15	1 0.1-1.0	3 0.3-3.0	5 3-30	7 6-60
	2 0.2-2.0	4 0.4-4.0	6 5-50	8 8-80
18	1 0.5-5.0	3 1-10	5 10-100	7 20-200
	2 0.6-6.0	4 1-15	6 15-150	8 25-250
20	1 1-10	3 2-20	5 20-200	7 30-300
	2 1-15	4 3-30	6 25-250	8 50-500
25	1 3-30	3 5-50	5 50-500	7 100-1000
	2 4-40	4 8-80	6 80-800	8 150-1500
32	1 5-50	3 10-100	5 150-1500	7 250-2500
	2 8-80	4 12-120	6 200-2000	8 300-3000
40	1 10-100	3 20-200	5 250-2500	7 350-3500
	2 15-150	4 25-250	6 300-3000	8 400-4000
50	1 15-150	3 25-250	5 350-3500	7 450-4500
	2 20-200	4 30-300	6 400-4000	8 500-5000

MATERIALS

BODY	FLOAT	TUBE	SEAL	PROTECTOR
S SS 304	S	G GLASS	N NEOPRENE	S SS 304
W SS 316	W SS 316	P P.C (POLY CARBONATE)	V VITON	A ACRYLIC
V P.V.C	T TEFLON		T TEFLON	P PAIND
P P.P	V P.V.C	S		ALUMINUM
D P.V.D.F	P P.P	W SS 316	ALARM	
X SS 316L	D P.V.D.F		N NO	L LO
C C.P.V.C	C C.P.V.C		H HI	A HI LO
O OTHERS				

SPECIFICATIONS

MODEL	PS	PW	PV	PP	PD	FO
MAX. TEMP	100°C		50°C	80°C	100°C	OTHER
MAX. PRESS	10kg/cm ² G		6kg/cm ² G		OTHER	
CONN. SCREW	A FPT		B FNPT		O OTHER	
ACCURACY	WATER 2% F.S		AIR 3% F.S			
GLASS	TEMP. 100°C		PRESS 4-6kg/cm ² G			
POLY CARBONATE	TEMP. 100°C		PRESS 6-12kg/cm ² G			

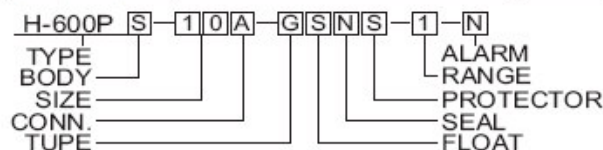

NOTE: 1.0 OTHERS FLOW RANGE

2. H-600P 型流量計是直接垂直安裝於管路上，流體底部進，上部出。

歡迎訂製各式特殊流量計，敬請惠予告知下列之條件：

1. 型式 (Model)
2. 流體 (Fluid)
3. 材質 (Material)
4. 流量範圍 (Flow Range)
5. 接續方式 (Connection)
6. 操作壓力 (Operating pressure)
7. 操作溫度 (Operating temperature)
8. 濃度及黏度 (Concentration & Viscosity)
9. 比重或密度 (Specific Gravity & Density)