

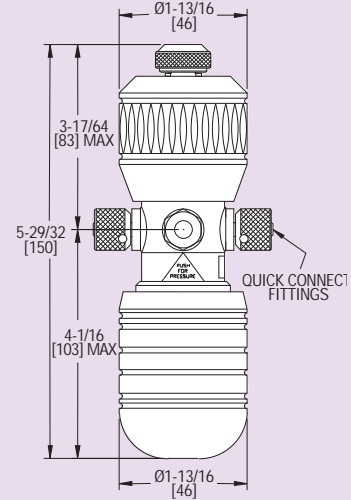

Model
HP

Hand Pump

Generates Pressures up to 45 psig (3 bar), Single Hand Operation



Model HP Hand Pump provides a dual source of pneumatic pressure and vacuum for verifying the calibration of pressure instrumentation. Pump can generate pressures up to 45 psig (3 bar) and vacuum to -27 " Hg (-910 mbar). The compact pump is designed for portability and single hand operation.

Model HP features a pressure relief valve and fine adjustment for control better than 0.0015 psi (0.1 mbar). Pump includes two 39" (1 m) hoses terminating in 1/4" female NPT connections and instruction manual.

Model HP-1, Hand Pump

ACCESSORIES

Model HP-1K, Service Kit

Model HP-1C, Hard Case

SPECIFICATIONS

Output Ranges: -27 " Hg to 45 psig (-910 mbar to 3 bar).

Process Connection: 1/4" female NPT (quick fit).

Fine Adjustment: Better than 0.0015 psi (0.1 mbar).

Materials: Nickel plated brass and anodized aluminum.

Weight: 20 oz (587 g).