

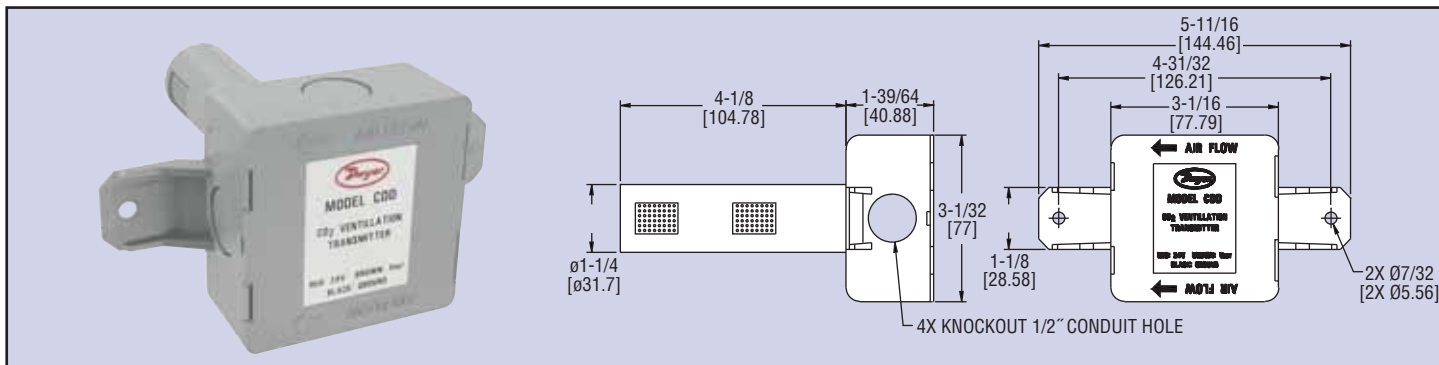

Model  
CDD

# Duct Mount Carbon Dioxide Transmitter

NDIR Sensing Technology, 2000 PPM Range



The Model CDD Duct Mount Carbon Dioxide Transmitter monitors the occupancy in a room by detecting the concentration of carbon dioxide in the return air duct. The non-dispersive infrared sensing technology automatically updates the calibration of the transmitter using a proprietary logic feature which limits the amount of error due to drift. The Model CDD can measure up to 2000 PPM in duct air flows less than 1500 FPM.

## Model CDD Carbon Dioxide Transmitter

### SPECIFICATIONS

**Range:** 0 to 2000 PPM.

**Accuracy:**  $\pm 40$  PPM + 3% of reading @ 22°C.

**Temperature Dependence:** 0.2% FS per °C.

**Stability:** < 2% of FS over life of sensor.

**Non-Linearity:** < 1% of FS.

**Pressure Dependence:** 0.13% of reading per mm of Hg.

**Response Time:** 3 minutes typical for 90% step change.

**Duct Air Velocity Range:** 0 to 1500 FPM (7.63 m/s).

**Ambient Operating Temperature:** 32 to 122°F (0 to 50°C).

**Storage Temperature:** -4 to 158°F (-20 to 70°C).

**Power Requirements:** 18 to 30 VAC RMS 50/60 Hz or 18 to 42 VDC.

**Power Consumption:** 1.65 watts peak (0.65 watts average at 42 VDC).

**Outputs:** 0 to 10 VDC.

**Housing:** Flammability Classification UL rated 94V-5.

**Weight:** 8 oz (230 g).