



Easidew

Transmitter

From the Impedance Range

A low cost, 2-wire, rugged impedance dew-point transmitter for continuous measurement in compressed air or process gas



Easidew Transmitter

Features

- Calibrated -100 to +20 °C dp
- 4-20mA linear output configurable within ranges:-
 - Dewpoint (-100 to +20 °C)
(-148 to +68 °F)
 - Moisture content (0-3000ppm(v))
- 2-wire and 3-wire operation
- Fast and reliable
- Small footprint. (Weighs only 150 g)
- IP66 and NEMA 4
- 12 to 28 V dc operation
- Reverse polarity protected
- Pressures up to 40MPa

Design Simplicity and Economy

The Easidew Transmitter is designed for ease of use, incorporating all the features you want to make installation and operation as simple as possible. For the first time, dew point measurement is made as accessible as temperature and pressure with this fully configured, calibrated transmitter that can be instantly incorporated into your air or gas management and control system.

Easidew Transmitter is also economical to buy, install and operate. Installation costs are minimal because of its ruggedness and simplicity. On-going operating costs are low, because Easidew Transmitter is very reliable and stable. Only periodic re-certification is required to maintain your traceability. We can even organise an exchange programme for you so that your process is never out of operation.

Now with 2 Wire Connection Capability

The Easidew Transmitter can now be connected in a 2-wire loop powered configuration whilst maintaining complete backwards compatibility with all existing 3-wire installations.

Advanced Technology

The key to the Easidew Transmitter's performance is its sensor technology. Michell's Advanced Ceramic Moisture Sensor is coupled with the latest microprocessor based measurement circuitry to produce a fully calibrated and interchangeable sensor transmitter. All calibration data is stored within the transmitter's flash memory and so calibration exchange or service can be effected in seconds, even by untrained personnel. The Easidew Transmitter is simply disconnected, removed from its sampling block and replaced by a new, fully calibrated unit. Furthermore, the Easidew Transmitter forms the front-end of both the Easidew On-Line and Portable Hygrometers. Total flexibility, interchangeability and ease of implementation.

Air and Gas Quality Measurement

The Easidew Transmitter is calibrated traceable to International Standards in Michell's UKAS accredited laboratory at thirteen points over the range -100 to +20 °C dew point, to an accuracy of ± 2 °C dew point. The inherent stability of our advanced Ceramic Moisture Sensor means that the Easidew Transmitter will give years of reliable operation, with only the need for a periodic calibration to maintain traceability - vital for conformance with your own quality standards. Easidew Transmitter is also fast to respond, ensuring that your process is always monitored in real time.

Simple Operation

Easidew Transmitter is so easy to install and operate. Powered by any dc source from 12 to 28 volts, it provides the user with a linear 4-20 mA signal. This output can be configured by the customer, using simple software, to represent any range within -100 to +20 °C, or -148 to +68 °F dew point, or 0 - 3,000 ppm(v). So, once the input and output connection is made, the transmitter only needs a sample of clean air or process gas and measurements can be taken. As the Easidew Transmitter measures the water vapour pressure in the gas sample, it will give the user an accurate determination of the actual dew point conditions presented to it - at any pressure up to 40 MPa. Flow rate is not critical to measurement accuracy (1 to 5 NL/min), though speed of response will of course be improved by operating a higher sample flow.

MICHELL
Instruments



The Dew Point Specialists



Rugged yet Lightweight

The Easidew Transmitter is constructed in 316 grade stainless steel, with a captive sealed, glanded cable connector and offers IP66 and NEMA 4 protection from the environment. This rugged construction makes it perfectly suited for industrial applications whilst, weighing only 150 g, it is light enough to be supported directly by its connection to a 6 mm or ¼ inch sample pipe without any additional mounting brackets. Again, design for operation is a key benefit.

Self-Diagnostics

In the unlikely event that something goes wrong, the microprocessor embedded within Easidew provides you with intelligent information on the failure mode. Sensor fault, under-range and over-range conditions are all signalled by pre-determined output levels so you can easily establish the source of the problem, rectify it and get back to operation as quickly as possible.

The Easidew Range

We offer a family of low cost hygrometer products based on our advanced ceramic technology providing on-line and portable dew point measurement. Because all three products use the same transmitter, interchangeability is made so simple. If you need to monitor various points in your process - some with local display, others with direct mA feed to a central control system, the Easidew range is ideal. The Easidew Portable Hygrometer allows local spot checks to be carried out when necessary, perhaps at the point of use of the air or process gas. Easidew On-Line Hygrometer provides continuous in-process measurement of gas dew point. In order to maintain traceability, you only need to stock one sensor type for all three products - the Easidew Transmitter. Call us for further information on the full Easidew Range.

From the Impedance Range

Technical Specifications

Sensor type	Michell Advanced Ceramic Moisture Sensor	
Calibration range	-100 to +20 °C dew point	
Power supply	12-28 V dc	
Output	4-20 mA current source, configurable over the entire range	
	Dewpoint -100 to +20 °C	
	-148 to +68 °F	
	ppm(v) 0 - 3000	
Accuracy	±2 °C dew point	
Operating temp	-40 to +60 °C	
Temp coefficients	Temperature compensated across operating temperature range	
Operating pressure	40 MPa,max.	
Flow rate	1 to 5 Nlmin ⁻¹ mounted in standard sampling block; 0 to 10 msec ⁻¹ direct insertion	
Interchangeability	Fully interchangeable transmitters	
Sensor Protection	HDPE Guard <10 µm 80 µm sintered guard (optional)	
Environmental protection	IP66 in accordance with standard BS EN 60529:1992, and NEMA 4 in accordance with standard NEMA 250-2003	
Weight	0.15 kg	
Fault conditions (factory programmed)	Condition	Output
	Sensor fault	23 mA
	Under-range dew point	4 mA
	Over-range dew point	20 mA

Easidew Transmitter Part Numbers

Standard Transmitter: EA2-TX

Non Standard Range: EA2-TX-w/xyz

w = Zero value

x = Full scale values,

y = Units (C = °C dp, F = °F dp & P = ppm(v))

z = Pressure for ppm(v) conversion in BarG. Blank = 0 BarG

Options:

Panel Meter - An economical panel or bench-mounted meter with digital display, analogue outputs and dual alarm relays. Display and output configurable as dewpoint (°C or °F) or ppm moisture content - Part number EA2-OL-100

Easidew Sampler - A self-contained sampling system, with filtration and flow control, for measurement of pressure or atmospheric dewpoint - Part number 9990278

Sample Block - Stainless Steel sample block to contain Easidew Transmitter, with 1/8" NPT ports - Part number - 9960665

Replacement HDPE Guard - Pack of 10 HDPE Guards - Part number - EA2-HDPE-10

Sintered Guard - Stainless Steel sintered guard, for protection of ceramic sensor (in place of standard HDPE Guard) - Part number 9980237

Dimensions

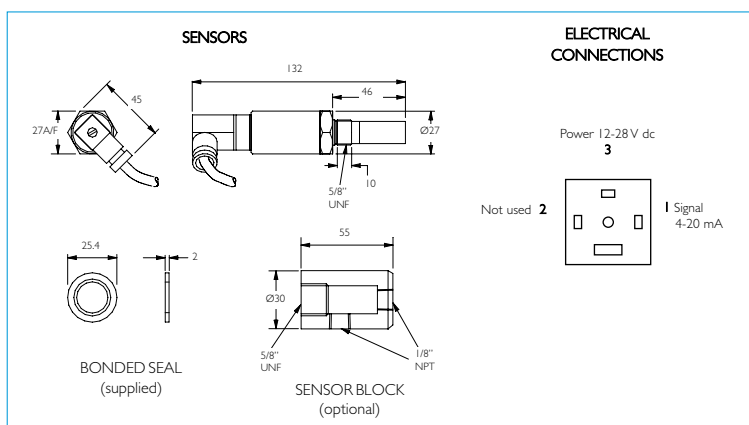

Dimensions mm

Easidew 2-Wire Transmitter - Ref. ET-10-06

Michell Instruments Ltd
 48 Lancaster Way Business Park, Ely,
 Cambridgeshire, CB6 3NW, UK
 Tel: +44 (0)1353 658000 Fax: +44 (0)1353 658199
 e-mail: info@michell.co.uk
 www.michell-instruments.com



Q6284 (UK)



0179 (UK)



The Dew Point Specialists