



Model
657C-1

Relative Humidity/Temperature Transmitter

Dual Channel Design for Simultaneous 4-20 mA Output Signals – Conduit Housing

Humidity &
Air Quality

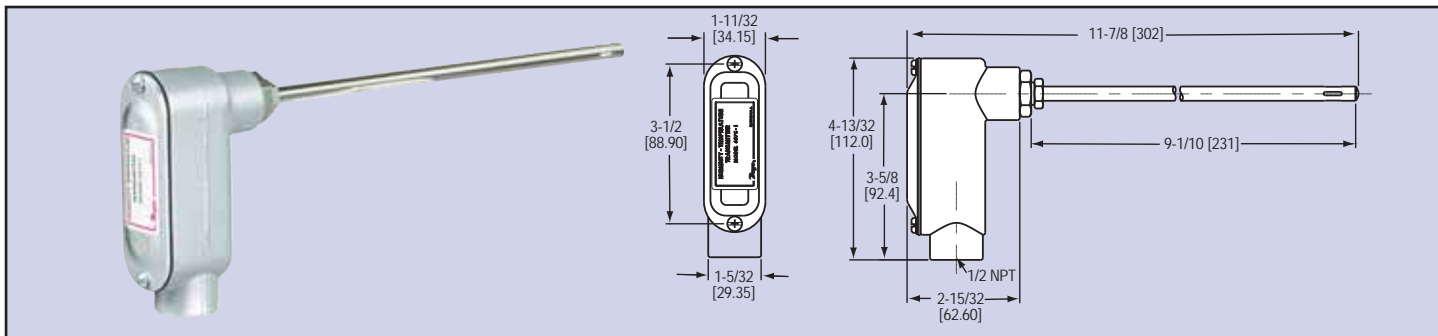

The Model 657C-1 Transmitter features the same circuit design as the 657-1 providing two 4-20 mA channels to produce separate output signals for both relative humidity and temperature. However, this model is housed in a tough die cast aluminum protective conduit enclosure with gasketed cover. An internal terminal block is provided for electrical connections. The sensor employed in the 657C-1 features a state-of-the-art integrated polymer film humidity sensor and a thin-film platinum temperature sensor to assure high reliability and rock-solid stability over years of continuous service. Stainless steel probe measures 5/16" x 9-1/10" (0.8 x 23.1 cm) and can be easily mounted to most ductwork using either of the two optional kits below.

657C-1 RH/Temperature Transmitter
A-158 Split Flange Mounting Kit
A-159 Duct Mounting Gland

SPECIFICATIONS

- Service:** Humidity & temperature detection in air.
- Range:** Relative Humidity: 0-100%; Temperature: 32 to 212°F (0 to 100°C)
- Accuracy:** Relative Humidity: ±2% (10-90% RH), ±3% (0-10% and 90-100% RH); Temperature: ±1°F (0.5°C).
- Temperature Limits:** 32 to 158°F (0 to 70°C).
- Pressure Limits:** 1 psi (.07 bar).
- Compensated Temperature Range:** 32 to 158°F (0 to 70°C).
- Power Requirements:** 10-35 VDC.
- Output Signal:** 2 channels each 4-20 mA. Loop powered on the RH channel.
- Electrical Connections:** 4 screw type terminal.
- Mounting Orientation:** Mount in any position.
- Probe:** 5/16" x 9-1/10" (0.8 x 23.1 cm) stainless steel.
- Weight:** 10 oz (284 g).